



**ADVANCED HARDWARE
TECHNOLOGIES**

Installation Instructions

AHT 9000 Series RIM Exit Device



**Read All Instructions Completely
Before Beginning Installation**

Step #1

Prepare lock stile.

Drill cylinder mounting holes if required.

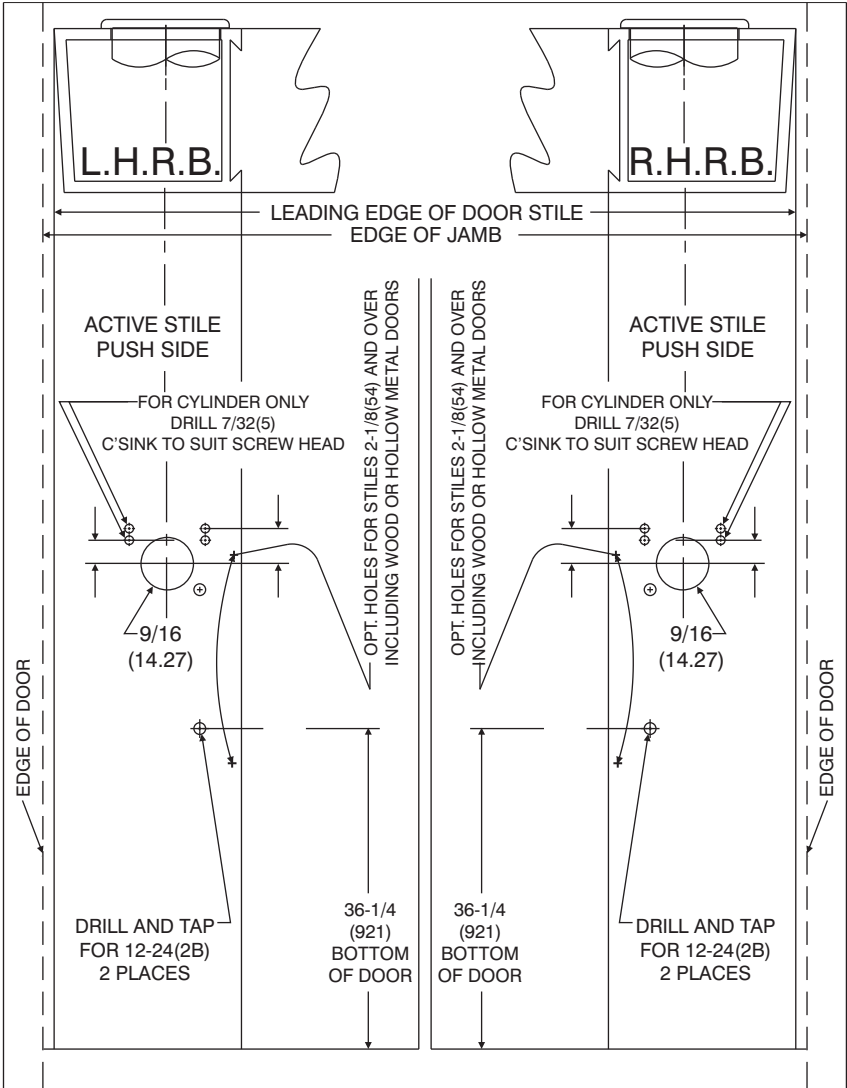

Step #2

Locate centerline of cylinder on exterior of door and drill if required.

Trim tail piece to fit into panic drive bushing assembly.

Mount cylinder and secure with mounting screws

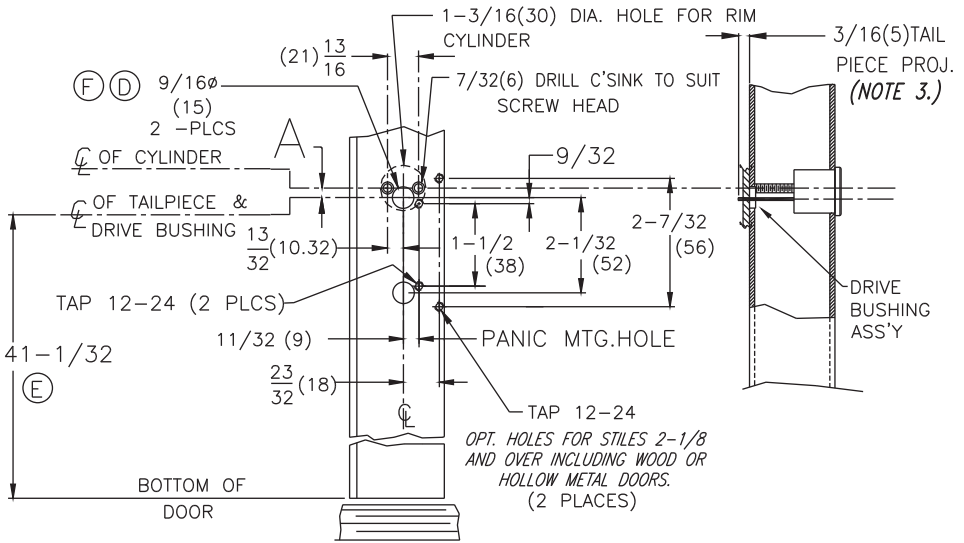

OFFSET HUNG INST.

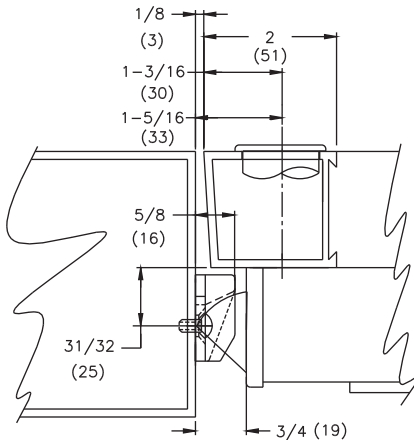

Step #3

Locate mounting hole on inactive stile.

Drill and tap 4/20 THDS. 40"(1016) from bottom of door.

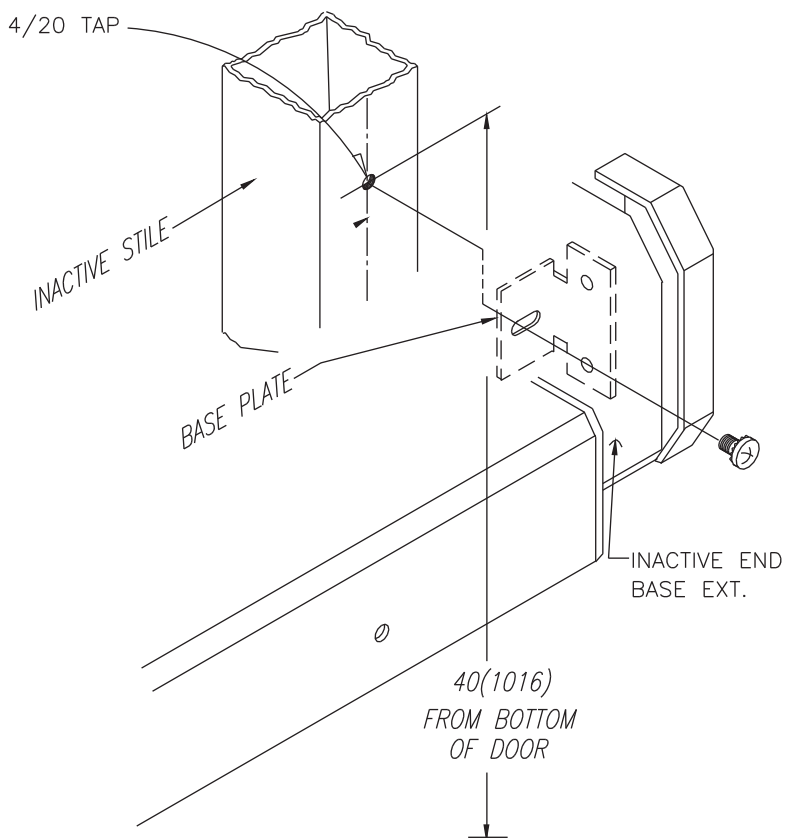

Step #4

Panic device attachment.

Remove front and rear end base covers by releasing 6-32 x 3/16(5) flat head screws.

Secure active end of panic by installing two 12-24x1/2(13) pan HD.M.S.

Secure inactive end with single 1/4-20x1/2(13) round HD.M.S. (phil.)
with SEMS through inactive base plate.

Proceed by re-installing filler plates and base covers on each end of panic base.

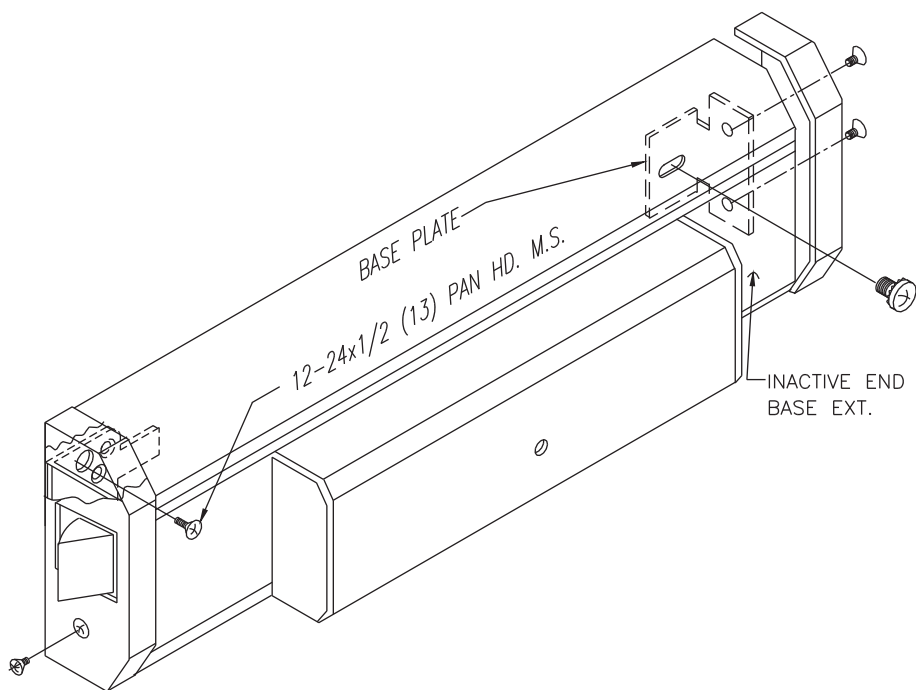

Step #5

Install strike.

To install strike, locate 10-24x5/8(16) taps on active stile (2 places)
Mount and secure strike.

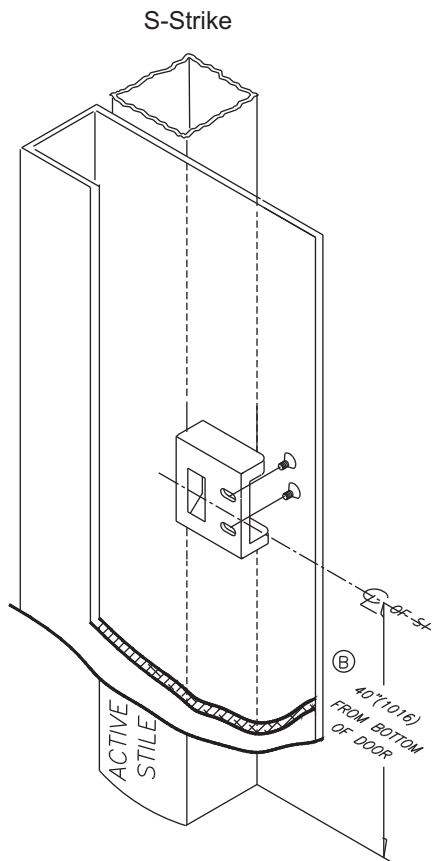
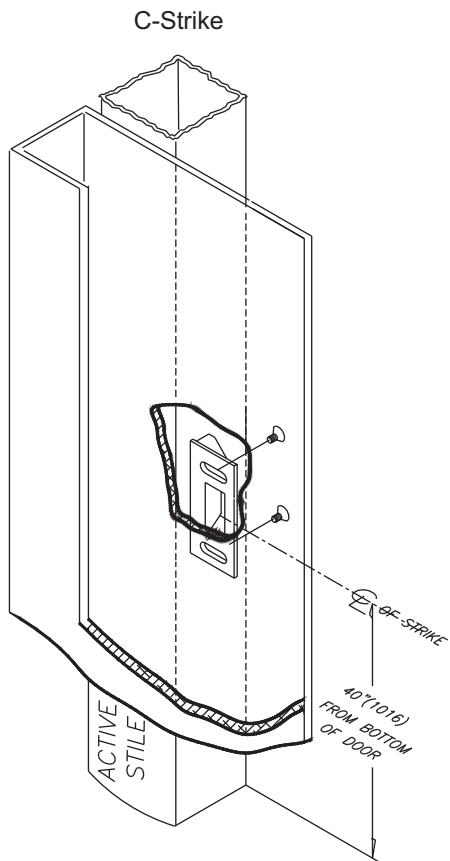

Step #6

Dogging Instructions:

TO DOG - Insert hex key turn clockwise until it stops, fully depress touch bar then release.

TO UNDOG - Insert hex key turn clockwise until it stops, touch bar will release.

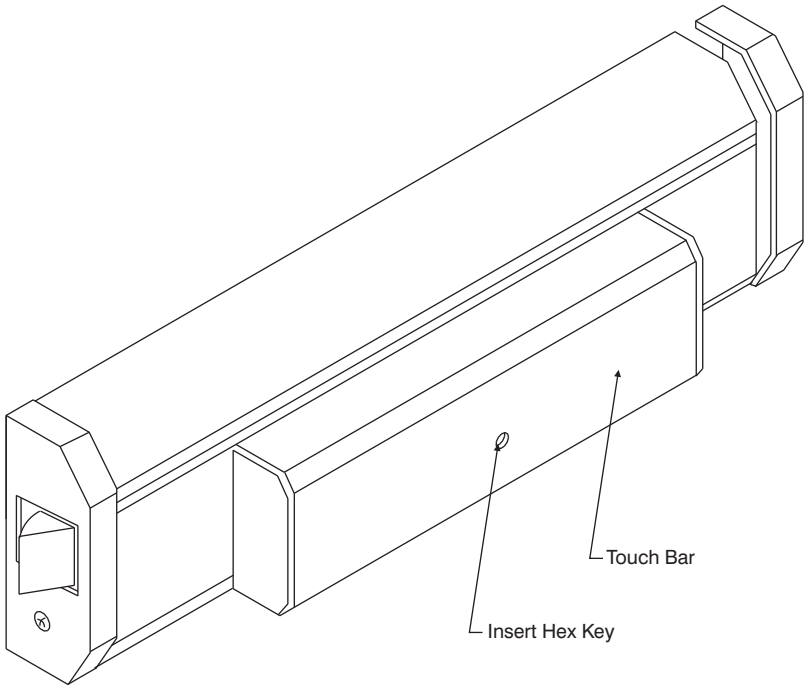



Advanced Hardware Technologies
15800 El Prado Road · Unit F · Chino, California 91708
T (866) 738-4916 · F (866) 798-0206
www.aht-tech.com · sales@aht-tech.com