



SYSTEM OVERVIEW

The MEL-1 motor retraction system has been designed to work specifically with the NP-1 power supply. The MEL-1 and the NP-1 each contain a computer that is constantly monitoring the status of the system. This communication is done using the RED and BLACK power wire that runs in between the NP-1 power supply and the MEL-1 retraction mechanism

FEATURES & SPECIFICATIONS

- Input voltage – 24-27.5 Vdc, 1.5 A
- Output rated 24-27.5 Vdc, 1.5 A
- (1) LEDS that monitor power
- (1) LEDS that monitor input status
- (1) LEDS that monitor:
 - RX status
 - Communication status
- Temperature range – 0 to 49 C

KIT CONTAINS

1. Motor Assembly
2. Replacement end cap
3. Wire Harness

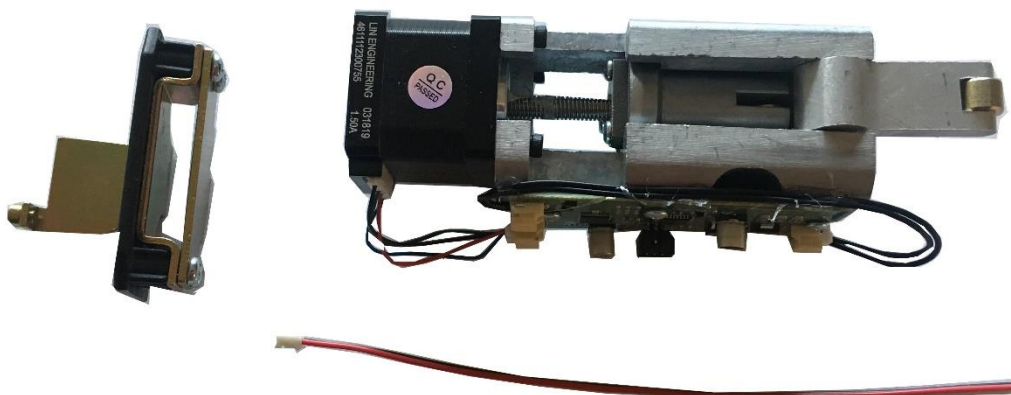

1. Remove the two screws that hold the bar end cap in place.

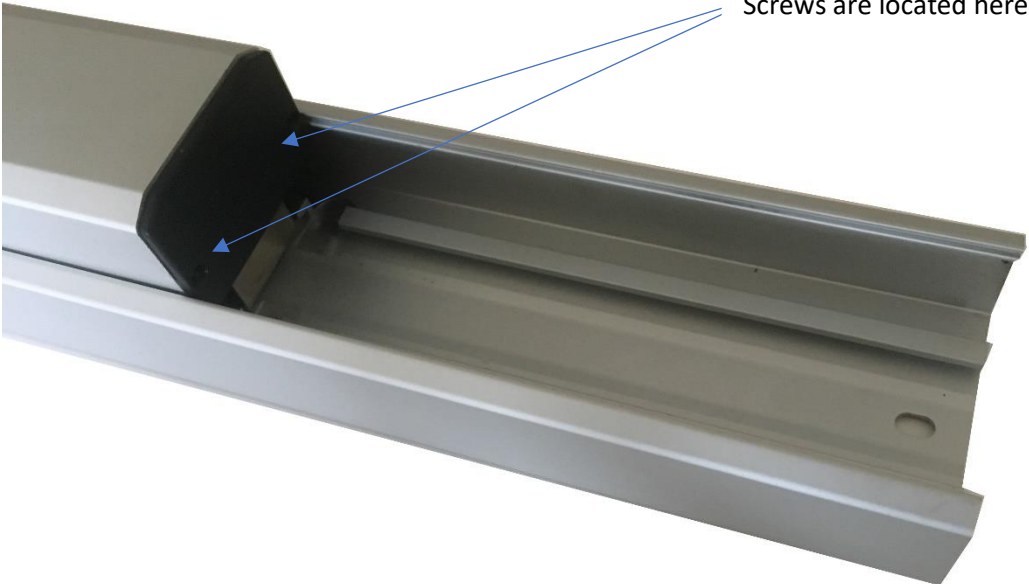

2. Slide the push bar slightly away from the end cap

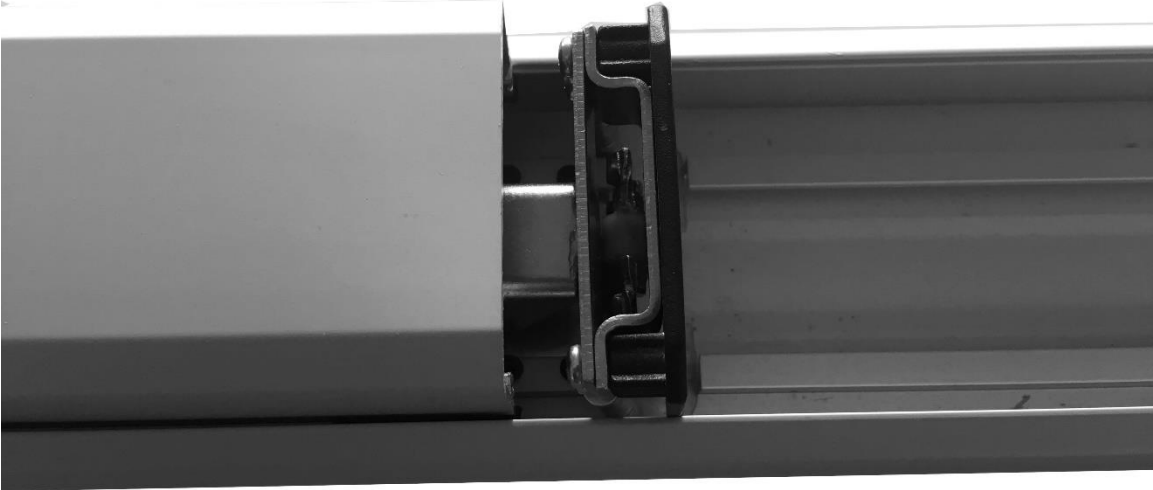

- 3. Lift the old end cap off the roller. Please pay attention to the way the end cap is installed over the roll, so you can install the new end cap in a similar fashion.**

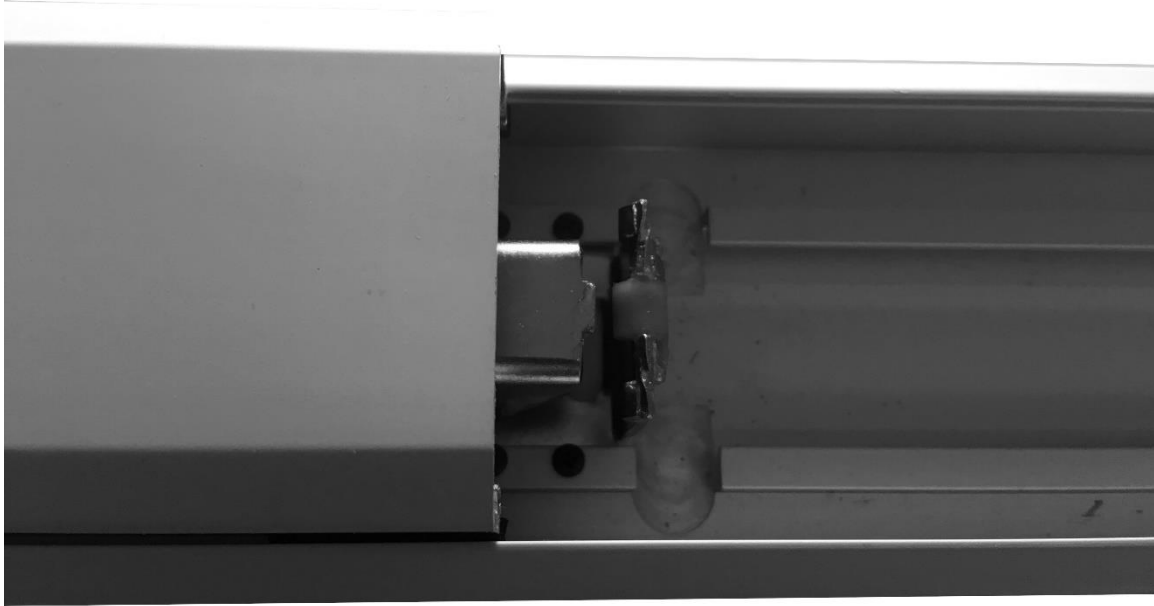

- 4. Replace the old end cap with the new end cap included in the kit**

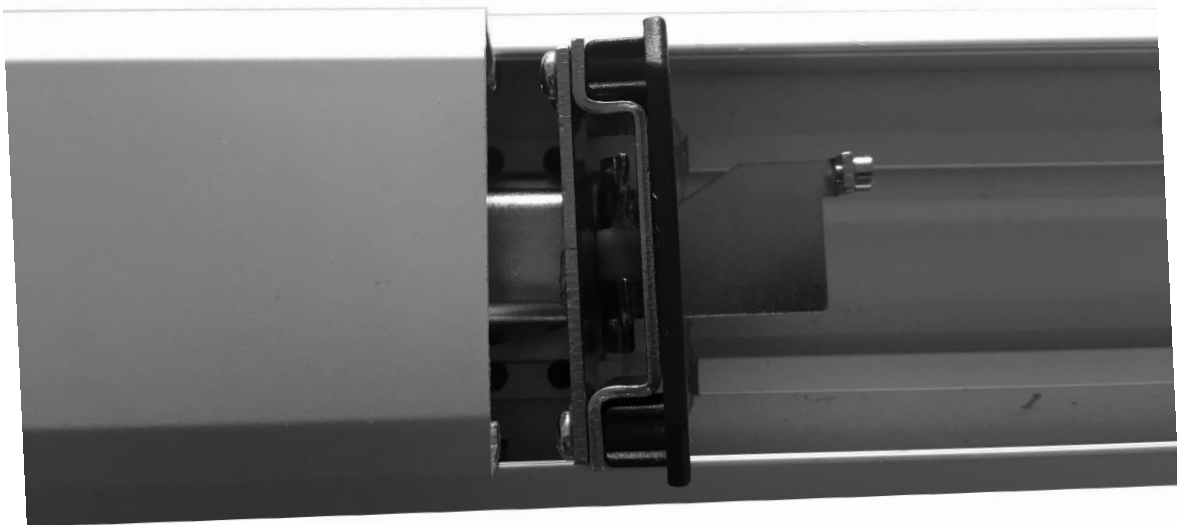

5. Slide the bar back over the end cap and install the two screws that were removed earlier

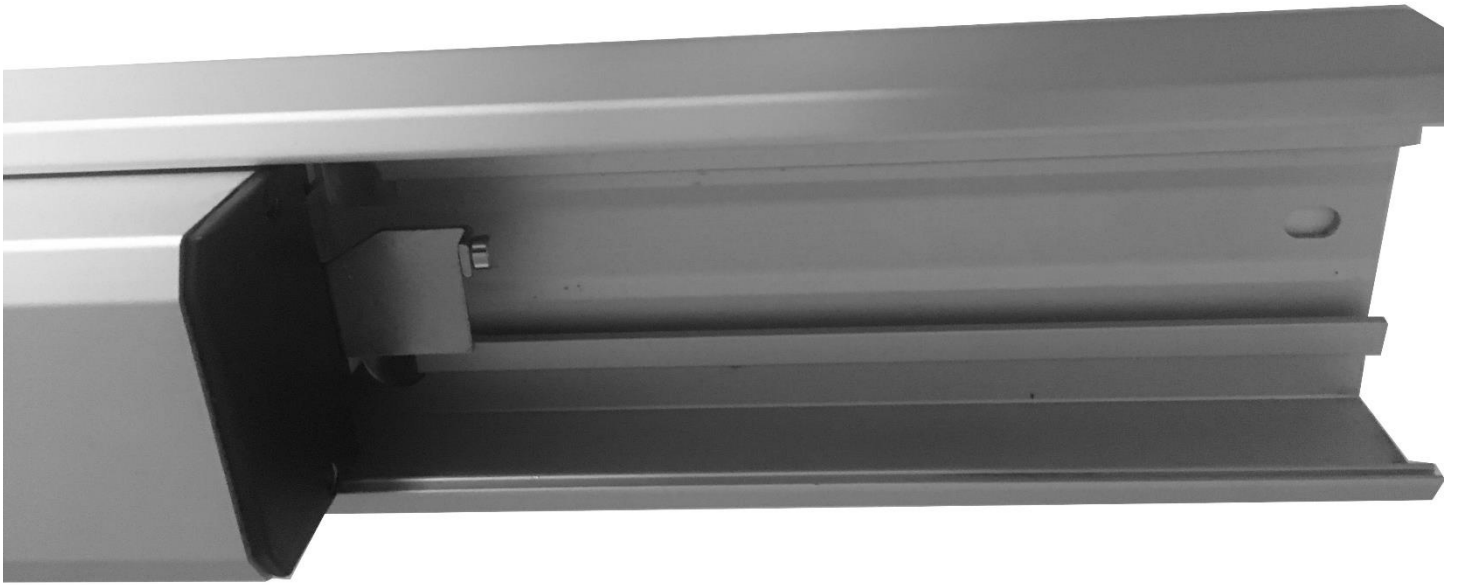

6. Before the installation of the motor mechanism. Make sure the set screws are backed out enough to easily slide into the exit device. There is a set screw on each side of the mechanism. (One screw is behind the PCB board)

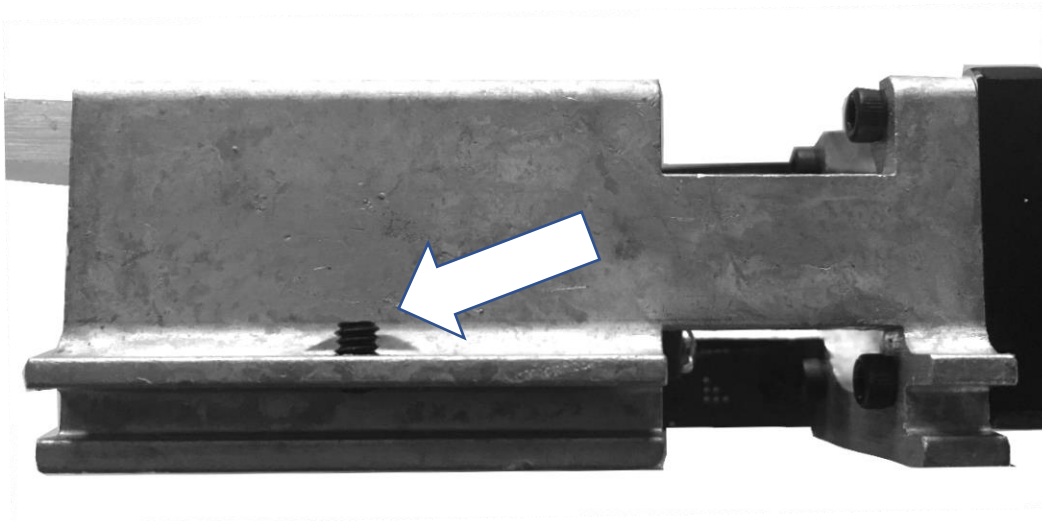

7. The kit comes with a red and black wire with a connector. Install the connector into the PCB on the side of the motor assembly.

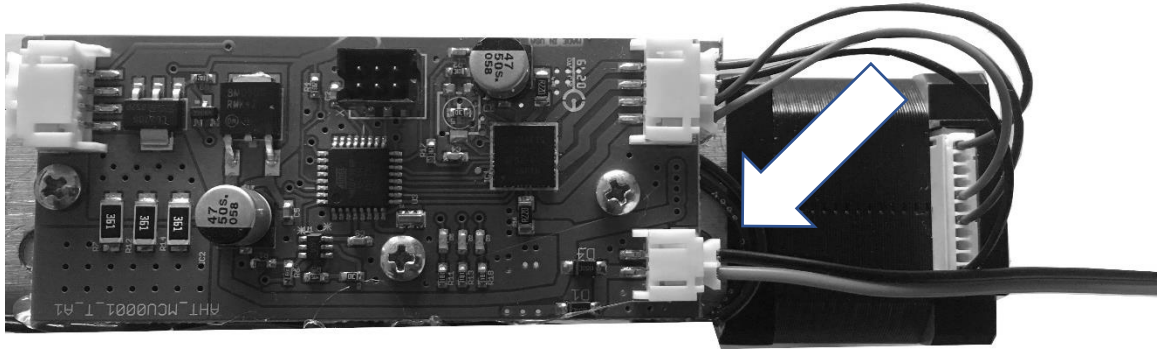

8. The slots on the motor assembly corresponds with the slots on the end of the exit device. Slide the motor assembly into the end of the device.

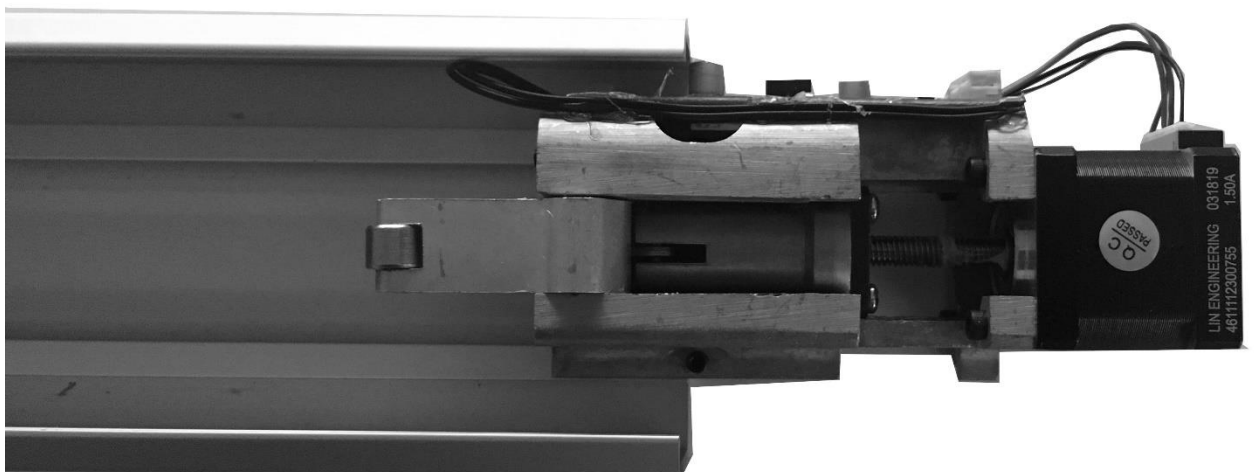

9. Slide the motor assembly into the bar, so it is within 1/8 of an inch from the end cap bracket when the push bar is depressed. Make sure that the push bar can move up and down freely with out anything coming in contact with the motor assembly.

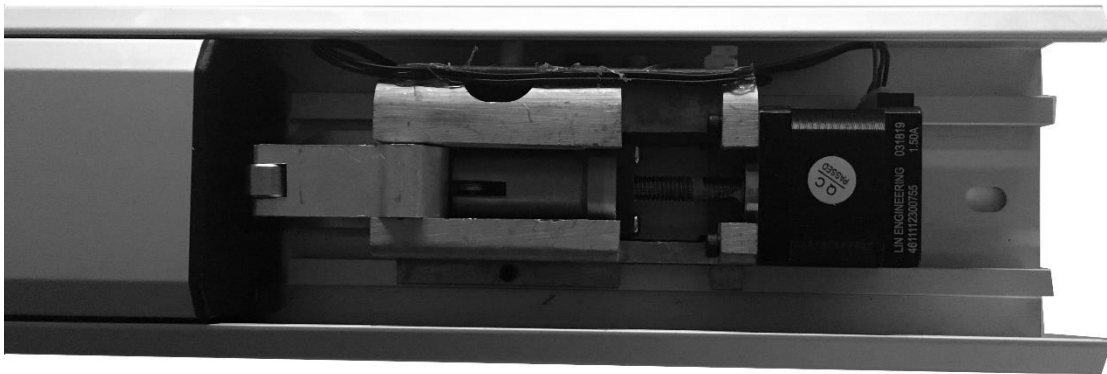

10. Tighten the two set screws.

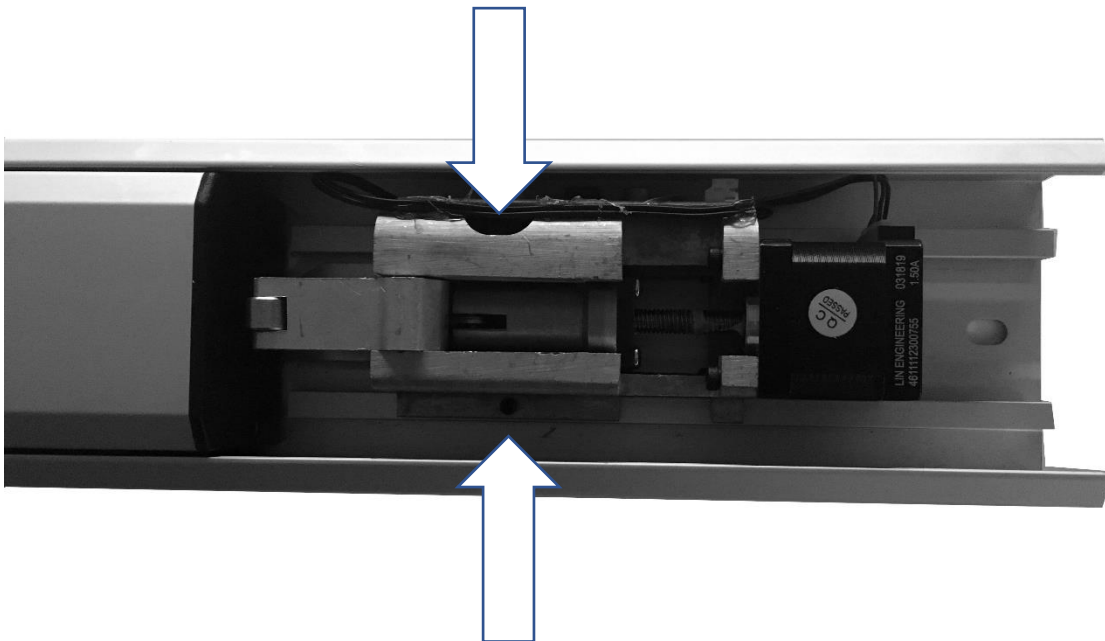

The installation is complete